



# 1 Door Robe Unit

## IMPORTANT

Before Commencing Assembly:

- Read all instructions COMPLETELY
- Ensure all listed parts are present  
If any parts are missing from Parts List 1, please contact 1800 822 823.

If any parts are missing from Parts List 2, please Contact HAFELE, Australia at 1300 559 387.

- Ensure you have the required tools to complete the assembly  
(Philips Head Screwdriver, Hammer & Wood Glue)

## CAUTION

- Ensure your work surface is solid, level, clean and flat (DO NOT WORK ON CARPET)
- Ensure ALL melamine edges are facing as described in the Assembly Instructions.

IF YOU NEED TO CONTACT US WITH REGARD TO THIS PRODUCT PLEASE CALL **1800 822 823** AND QUOTE THE BATCH NUMBER SHOWN ON THE CARTON.

**WARNING: Contains small parts, keep out of reach of children.**

615 Goodwood Road, Panorama SA 5041  
PO Box 18 Melrose Park SA 5039  
Telephone: 1800 822 823, Fax: (08) 8460 0009  
Email: [furniture@bedfordgroup.com.au](mailto:furniture@bedfordgroup.com.au)  
[www.bedfordgroup.com.au](http://www.bedfordgroup.com.au)

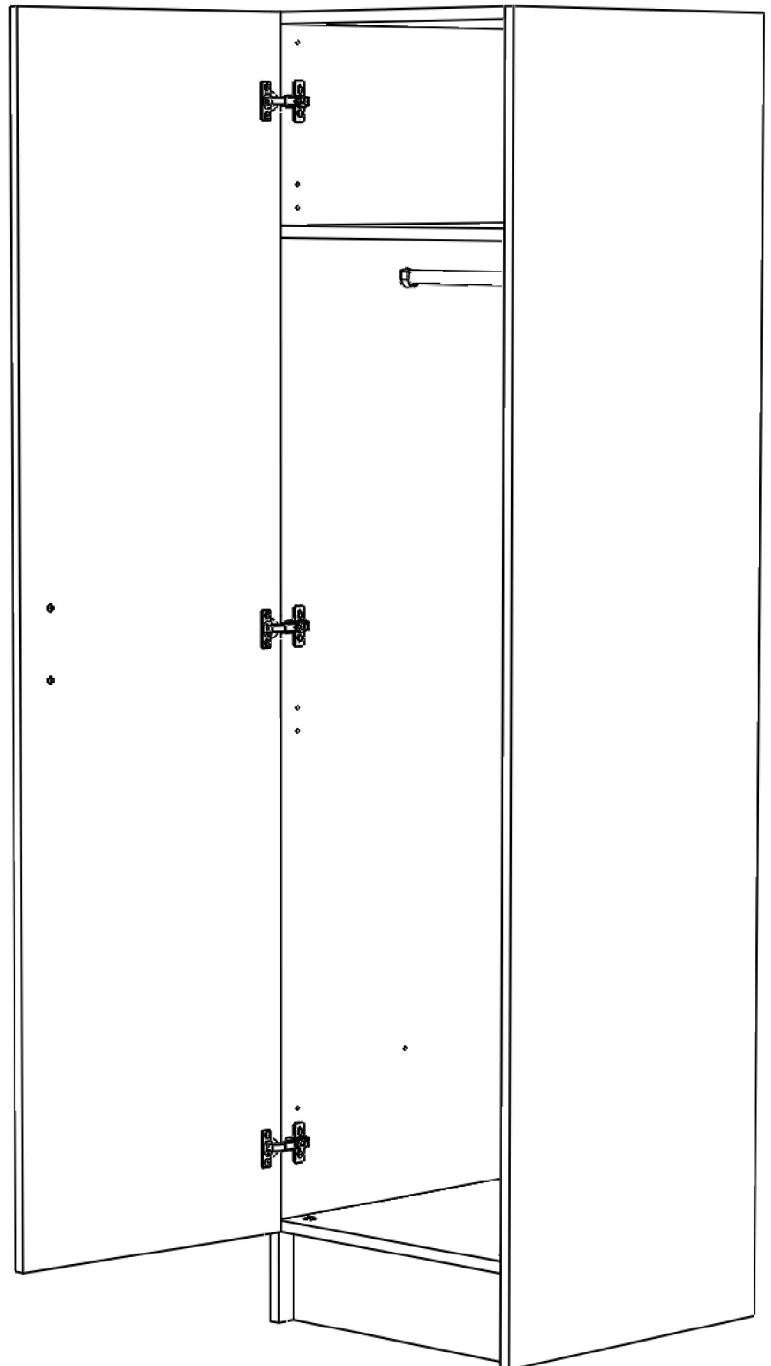

Quality  
ISO 9001



AUSTRALIAN MADE

SAI GLOBAL

**Practical, Adaptable, Affordable.**

READY TO ASSEMBLE HOME STORAGE SOLUTIONS

**Parts List 1**  
**1 Door Robe Unit**

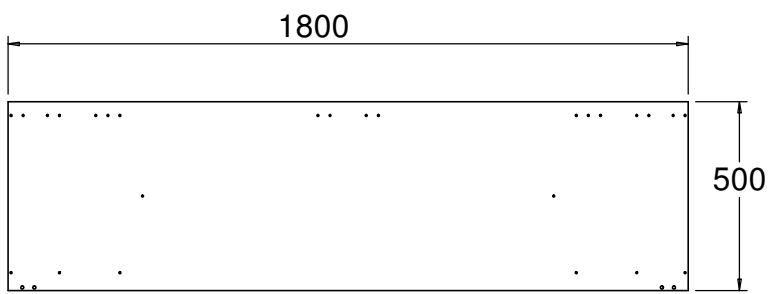
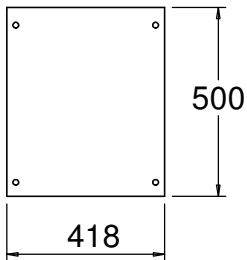

| Part No. | Description          | Qty. |
|----------|----------------------|------|
| 1        | Fix Shelf/Top/Bottom | 3    |

| Part No. | Description | Qty. |
|----------|-------------|------|
| 2        | Cabinet End | 2    |

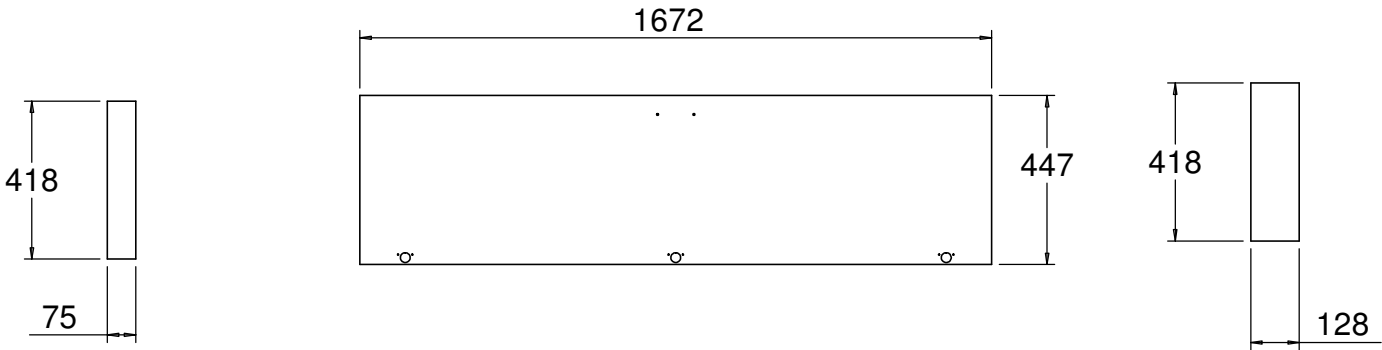

| Part No. | Description   | Qty. |
|----------|---------------|------|
| 3        | Top Back Rail | 1    |

| Part No. | Description | Qty. |
|----------|-------------|------|
| 4        | Door        | 1    |

| Part No. | Description | Qty. |
|----------|-------------|------|
| 5        | Toe Rail    | 1    |

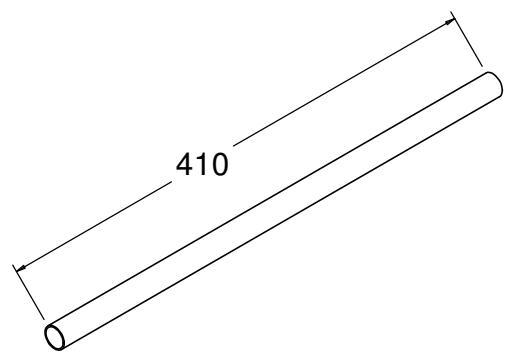
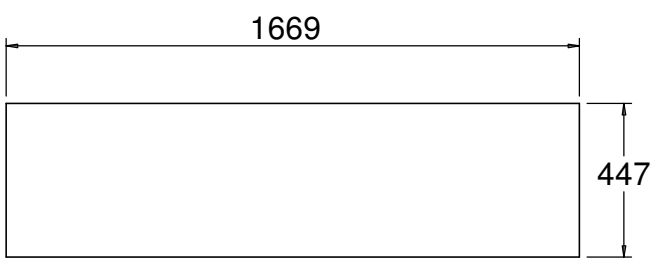

| Part No. | Description | Qty. |
|----------|-------------|------|
| 6        | Back        | 1    |

| Part No. | Description | Qty. |
|----------|-------------|------|
| 7        | Hanging Rod | 1    |

**Parts List 2**  
**1 Door Robe Unit**

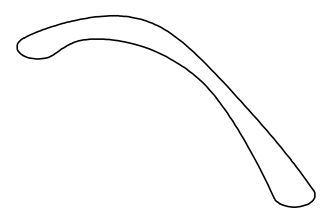
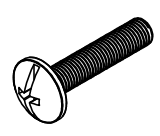
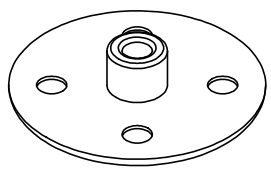

| Part No. | Description | Qty. |
|----------|-------------|------|
| 8        | Cover Caps  | 12   |

| Part No. | Description          | Qty. |
|----------|----------------------|------|
| 9        | Handle Screws (20mm) | 2    |

| Part No. | Description | Qty. |
|----------|-------------|------|
| 10       | Handle      | 1    |

# Parts List 2

## 1 Door Robe Unit

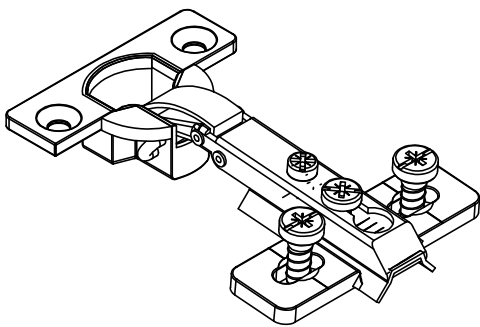

| Part No. | Description | Qty. |
|----------|-------------|------|
| 11       | Hinge       | 3    |

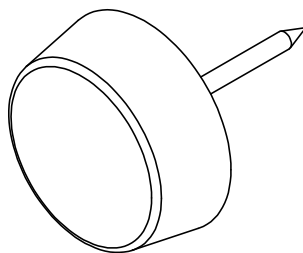

| Part No. | Description | Qty. |
|----------|-------------|------|
| 12       | Glides      | 4    |

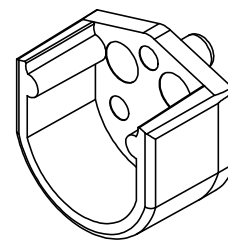

| Part No. | Description          | Qty. |
|----------|----------------------|------|
| 13       | Hanging Rod Supports | 2    |

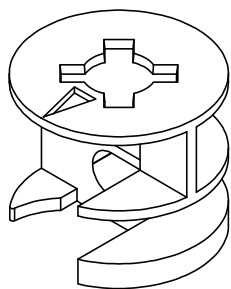

| Part No. | Description | Qty. |
|----------|-------------|------|
| 14       | Screw Cams  | 12   |

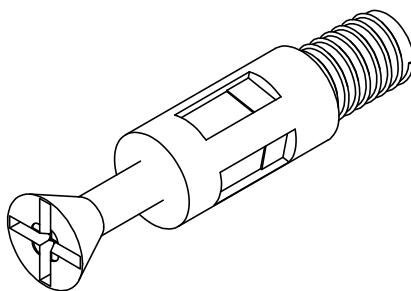

| Part No. | Description  | Qty. |
|----------|--------------|------|
| 15       | Hardware Pin | 12   |

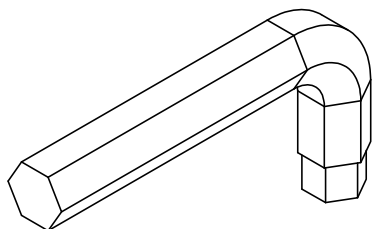

| Part No. | Description     | Qty. |
|----------|-----------------|------|
| 17       | Allen key (4mm) | 1    |

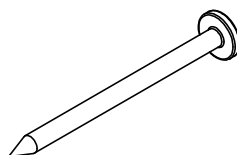

| Part No. | Description | Qty. |
|----------|-------------|------|
| 18       | Nails       | 25   |

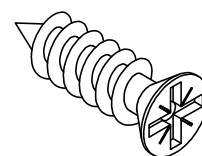

| Part No. | Description         | Qty. |
|----------|---------------------|------|
| 19       | Hinge Screws (15mm) | 6    |

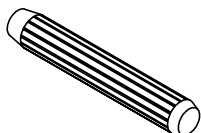

| Part No. | Description        | Qty. |
|----------|--------------------|------|
| 20       | Small Wooden Dowel | 4    |

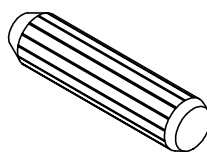

| Part No. | Description        | Qty. |
|----------|--------------------|------|
| 21       | Large Wooden Dowel | 4    |

## Step 1

### Cabinet end panel

Please lay left cabinet end panel (2) on a flat protected surface with holes facing up. Note that the left and right end panels are reversible. Screw the hardware pins (15) in the holes shown. Assemble the other cabinet end panel (2) in mirror image.

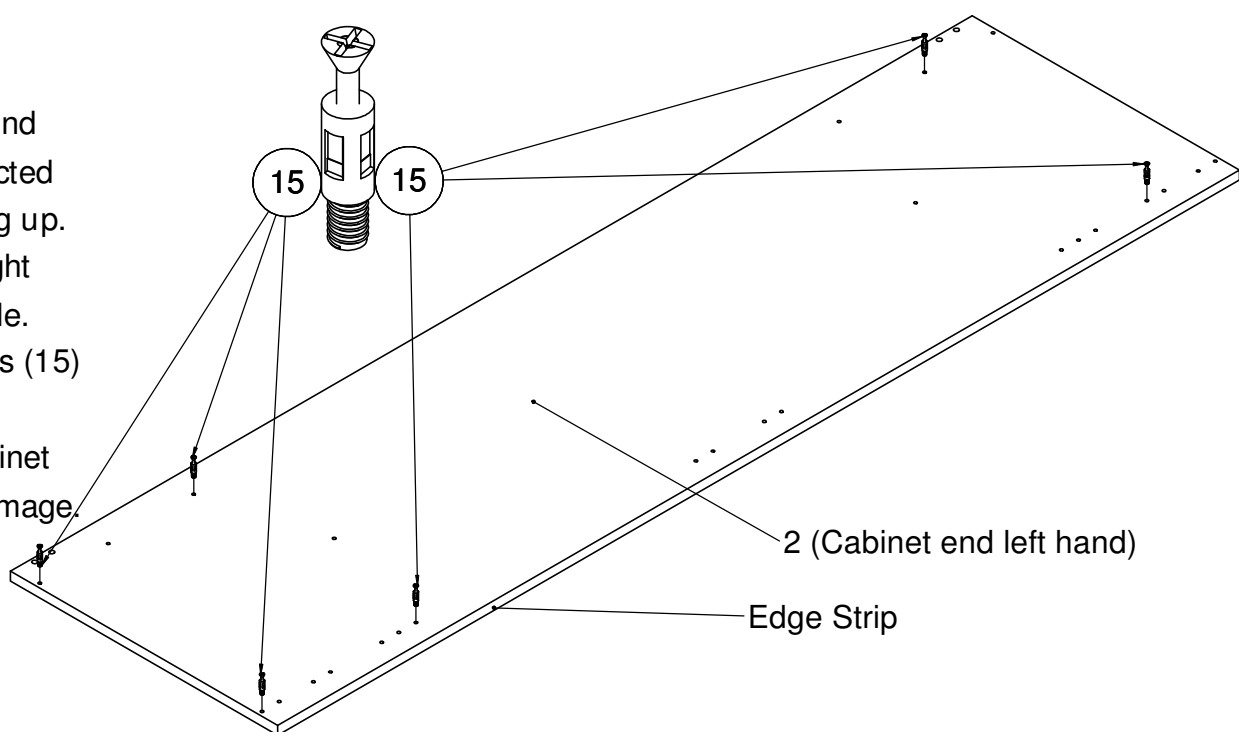

## Step 2

### Assembling hinge to the door panel and hinge plate to cabinet end panels

With the left cabinet end (2) lying flat and with its melamine edge facing toward the assembler, lay the door panel (4) next to the cabinet end panel as shown, making sure that the top of cabinet end panel (2) and door (4) is level. The door panel (4) can easily be identified by large 26mm diameter holes.

Loosen centre screw 2 and separate the hinge mounting plates from hinges. Attach hinge to the door panel (4) by positioning the body of hinge in large 26mm holes and secure in place using hinge screws (19). Secure the three hinge mounting plates on the cabinet end panel (2) in the holes directly opposite to the hinge in the door.

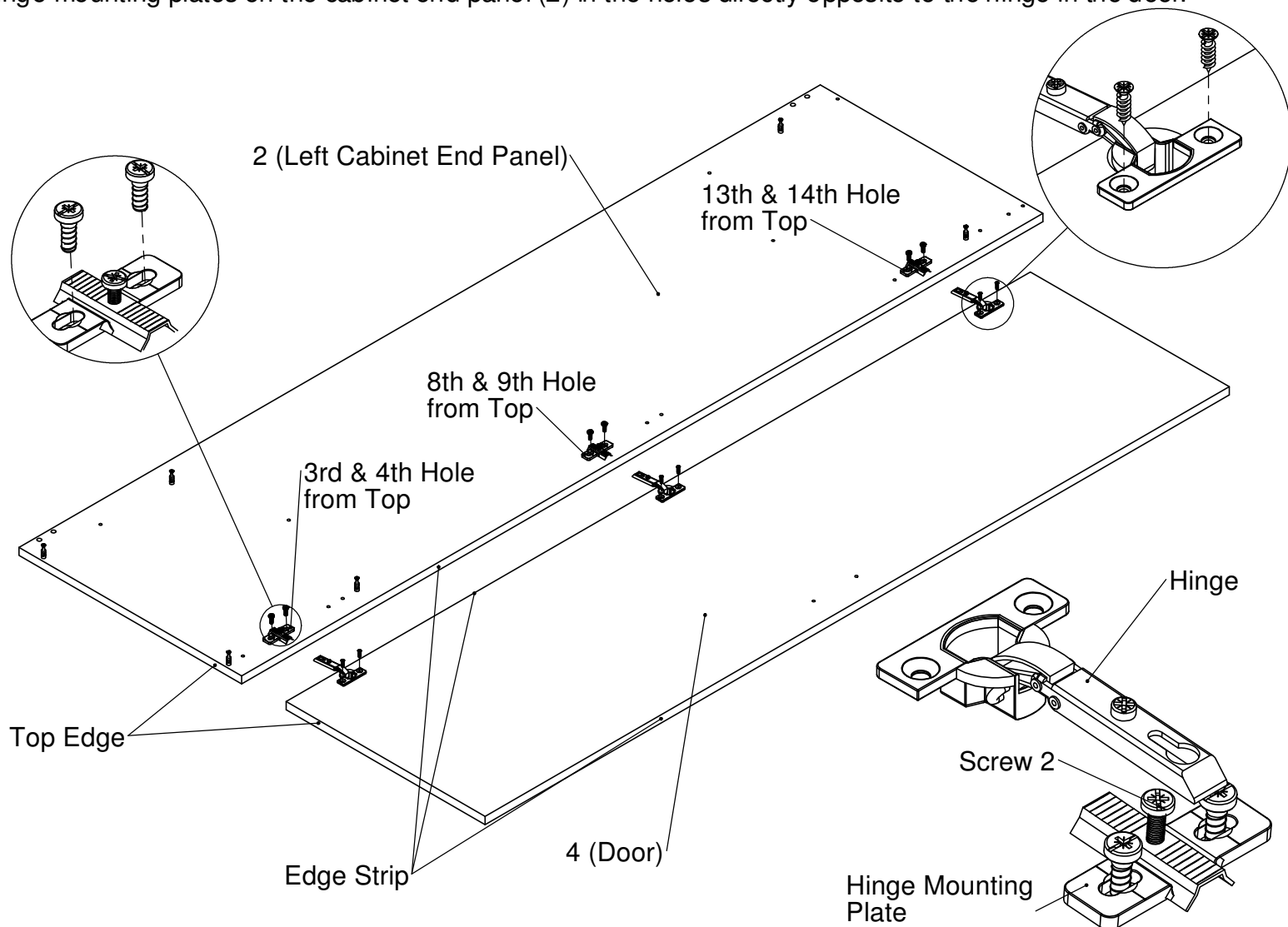

### Step 3

#### Shelf, top and bottom

Lay the top (1) on a flat surface with holes facing up and insert the cams (14) in holes with arrows pointing to the side of the top as shown. Please note that top, bottom and fix shelf are same. Make sure to push the cams (14) all the way in by gently taping them in with a hammer.

Repeat the step for top (1) and bottom (1).

### Step 4

#### Inserting dowels into rails

Please insert small wooden dowels (20) into toe rail (5) and large wooden dowels (21) into top back rail (3). It is recommended to use glue prior to inserting wooden dowels (20) and (21) into the holes (please remove excess glue with a damp cloth). Make sure to push the dowels (20) and (21) all the way in by gently tapping them in with a hammer.

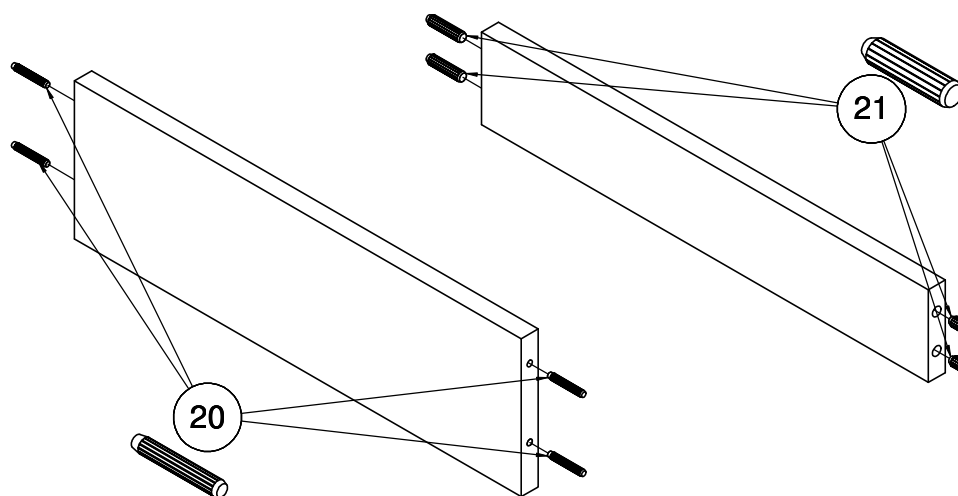
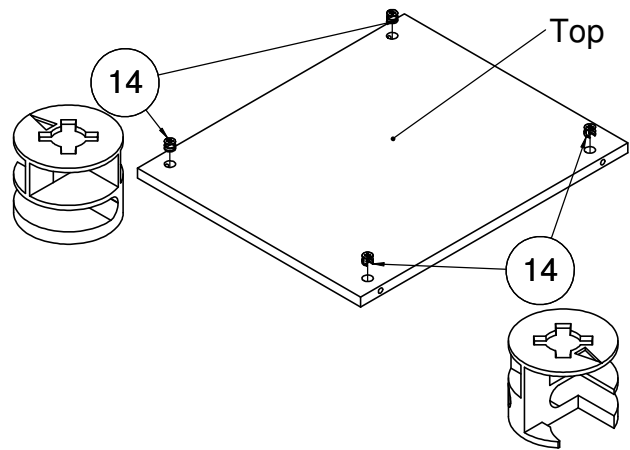

### Step 5

#### Assembling cabinet end, top/bottom/fix shelf and rails

With the left cabinet end (1) lying flat and with its melamine edge facing toward the assembler, attach the top and bottom (1) with the cabinet end making sure that the edge strip faces toward the front of the unit and cams are facing toward the top of the unit. Attach the fix shelf (1) to the cabinet end with cams facing to the bottom of the unit and edge strip face to the front of the unit. Lock in place by rotating cams (14) in clock wise direction by 180° using Allen Key (17).

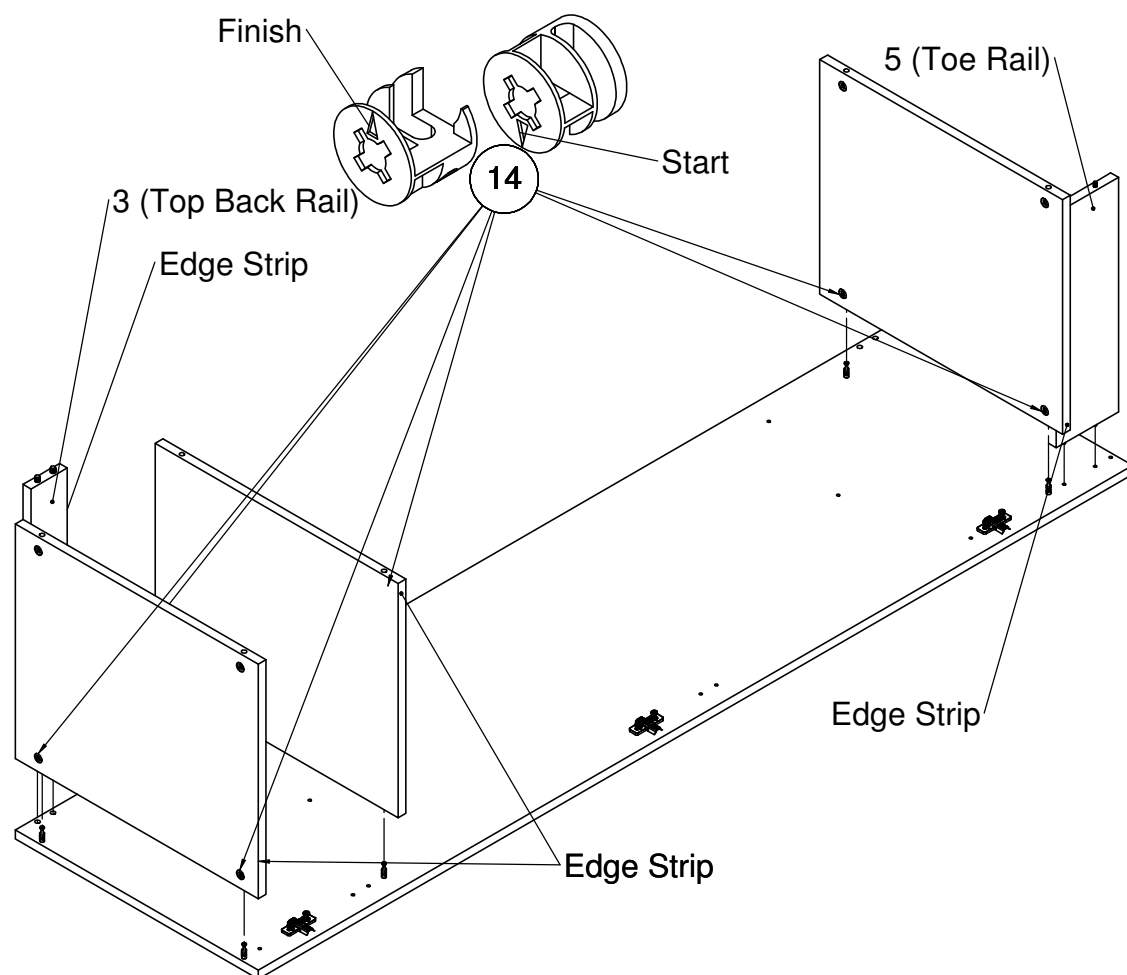

Fix the toe rail (5) and top back rail (3) to the cabinet end. It is recommended to insert small amount of glue in the dowel holes prior to inserting rails.

## Step 6

### Complete assembly without door

It is recommended to insert small amount of glue in the dowel holes in the cabinet end and making sure, that, all the hardware pins and dowel holes in the right cabinet end align with the above assembly and edge strip faces toward the front of unit, gently press the right cabinet end down so that it is completely pressed up along the top, bottom, fix shelf and rails (no gap). Lock the cams (14) in position by rotating clockwise  $180^{\circ}$ , using Allen key (17).

Fix the white cover caps (8) on the cams (14).

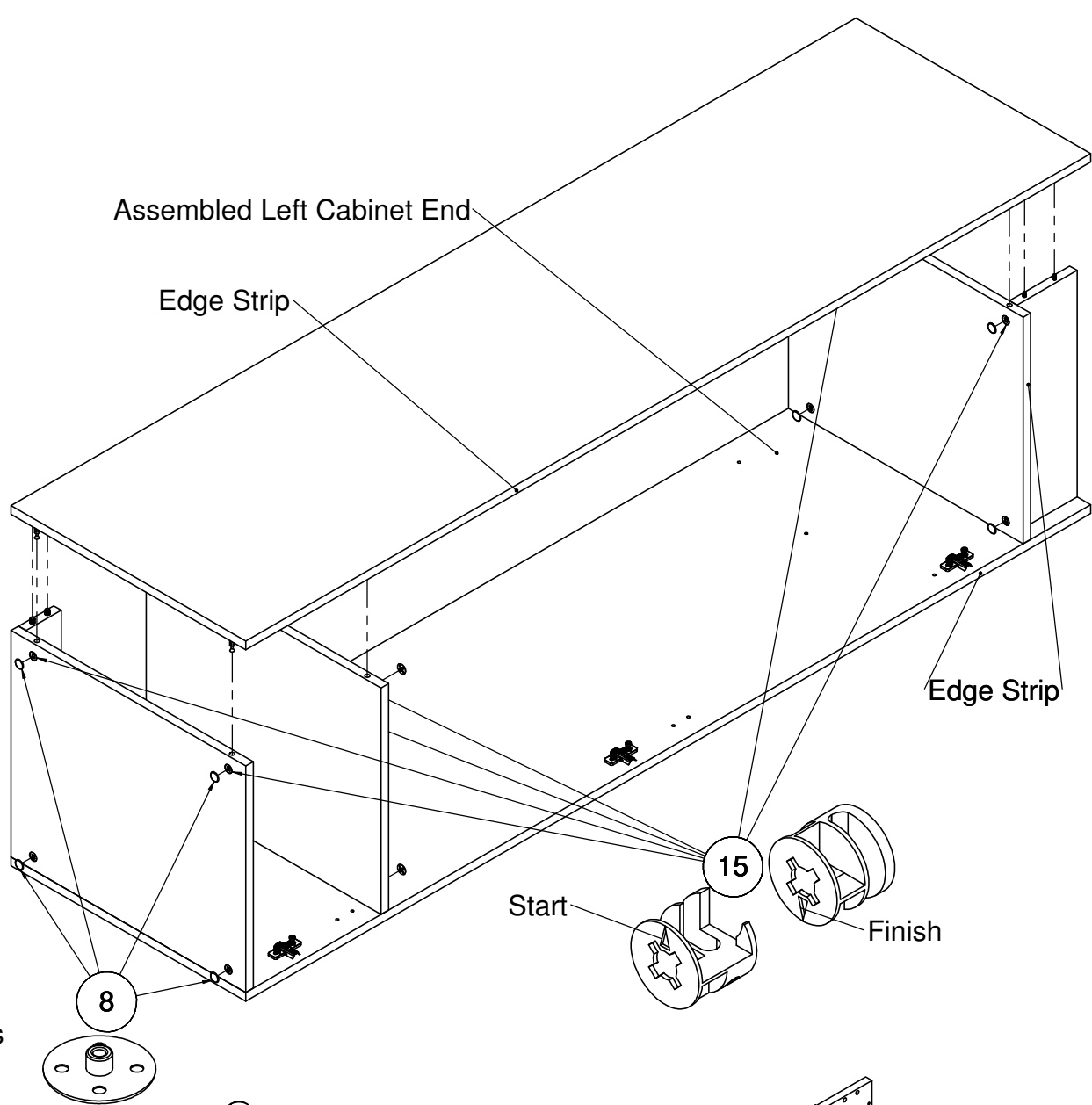

## Step 7

### Attaching the MDF Back

Lay unit face down on a protected surface to avoid damaging melamine edges and position the back panels (6) against the top rear of the unit (approximately 1.5 mm in from the top edge) with white side facing inward. Ensuring that the cupboard is square, nail (18) the back panel (6) along all the edges taking care to avoid nail breakage through the surface of the fix shelves and cabinet ends.

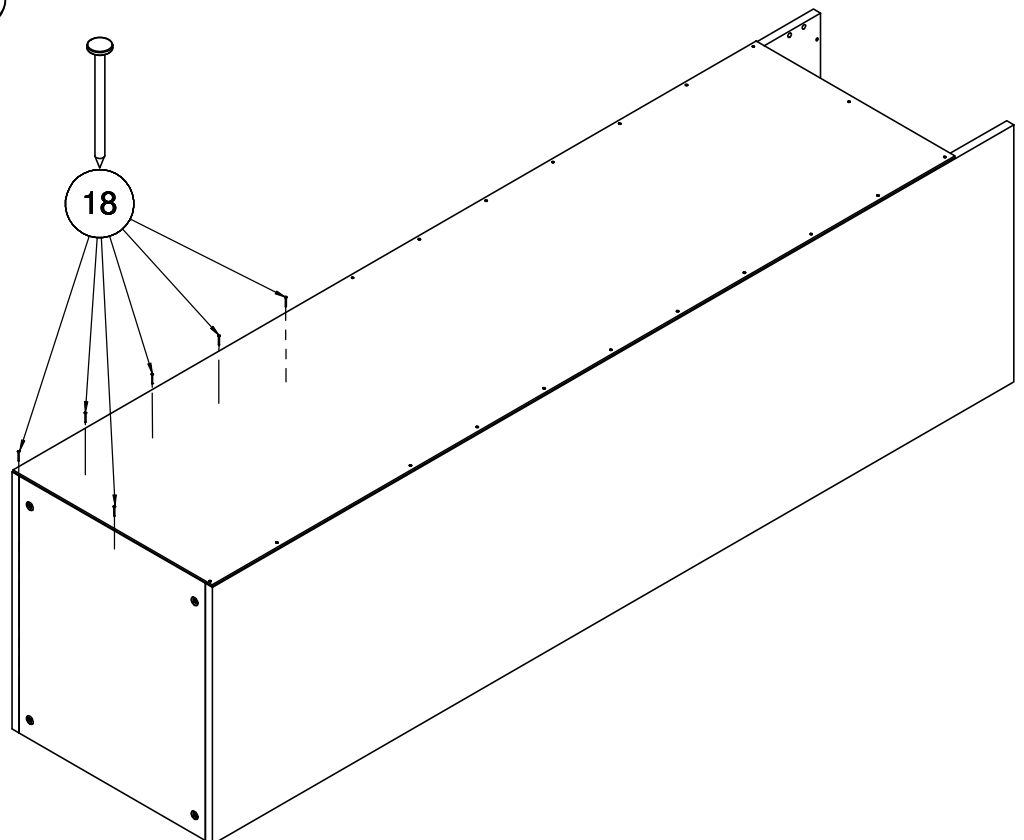

## Step 8

### Attaching the plastic glides

While unit is lying face down, attach the four glides (12) on the underside corners of the cabinet end panels.

## Step 9

### Assembling door to the unit and inserting robe rail

*Caution: If the unit is not secured to the wall. It may tip forward when, the cabinet is opened empty.*

Insert the hanging rod supports (13) into the holes shown and carefully insert the hanging rod (7) between the supports.

Hold the door straight against the unit so that the screw 2 in the hinge plates are in line with holes in the hinge and top edge of door is level to the top of the cabinet, tighten hinge screw 2.

Fix handle (10) onto the door using handle screws (9).

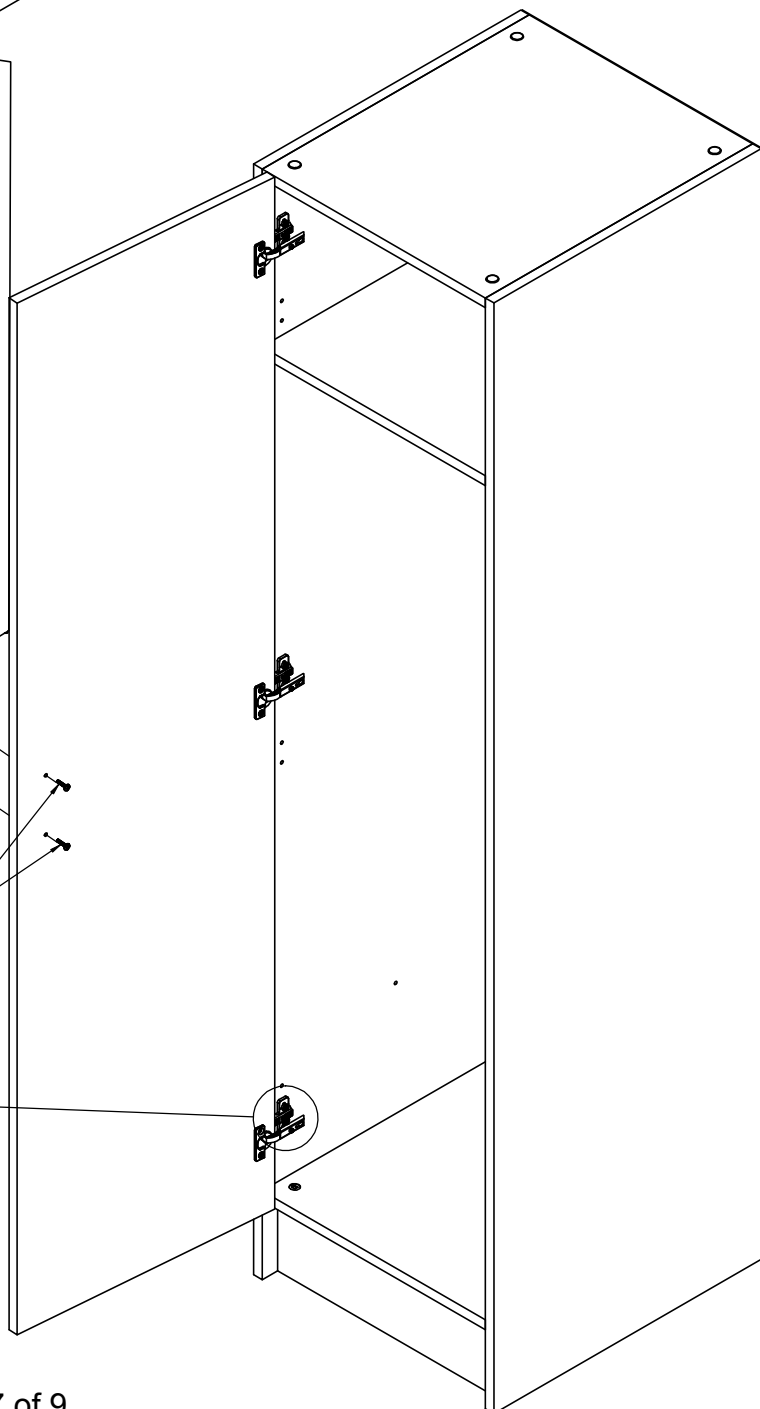
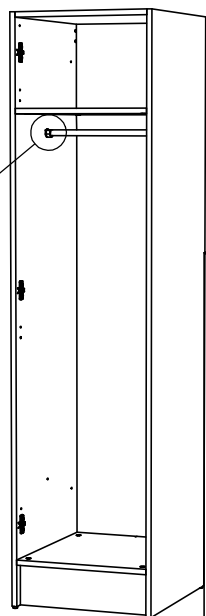
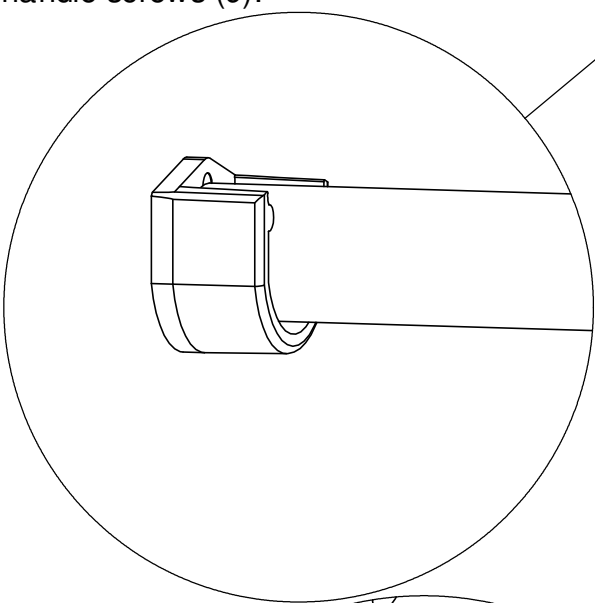
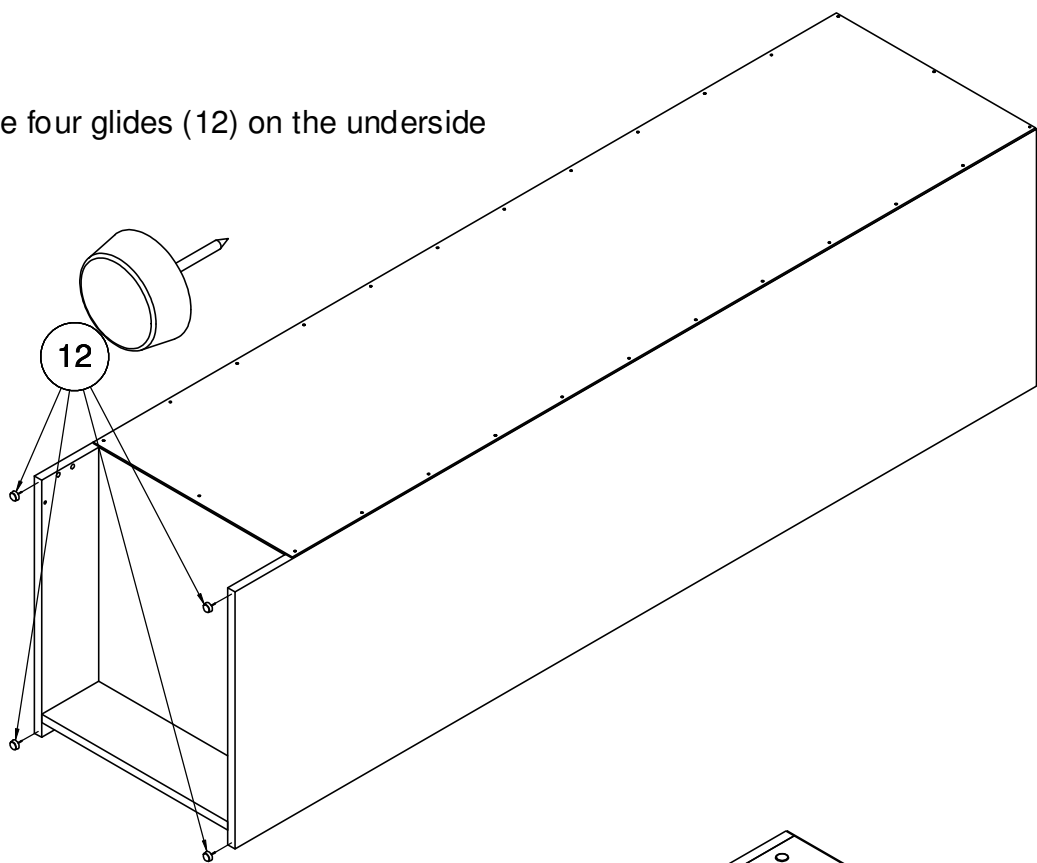

## Step 10

### Hinge adjustment

*Caution: The unit may tip forward when opened empty, if not secured to the wall.*

- Screw 1 is used for gap adjustment between cabinet end and door.
- Screw 2 is used to secure hinge to end.
- Screw 3 and 4 is used for gap adjustment between cabinet top and door as well as to secure hinge plate to cabinet end.

Following instructions should be followed to adjust hinges if the gap between the door and cabinet end is too wide or narrow:

1. Start from the top hinge.
2. Loosen screw 2 by turning screw in an anti-clockwise direction.
3. Now turn screw 1 in a clockwise direction (the amount to turn this screw is determined by the width of the gap between the door and the cabinet end).
4. Tighten screw 2 by turning in a clockwise direction.
5. Repeat these steps for the centre hinge and bottom hinge.
6. Check gap between cabinet door and the cabinet end (should be approx. 2mm), if not, repeat steps 1 to 5.

To adjust the gap between cabinet top and door (should be parallel), loosen screw 3 and 4 of top, middle and bottom hinge by turning screws in anticlockwise direction. Adjust the gap between cabinet top and top edge of the door. Once adjusted, tighten the screw 3 and 4 by turning in clockwise direction.

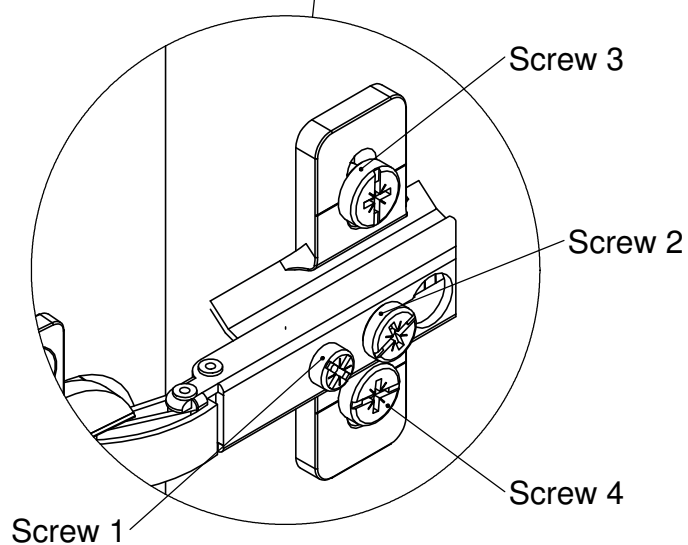
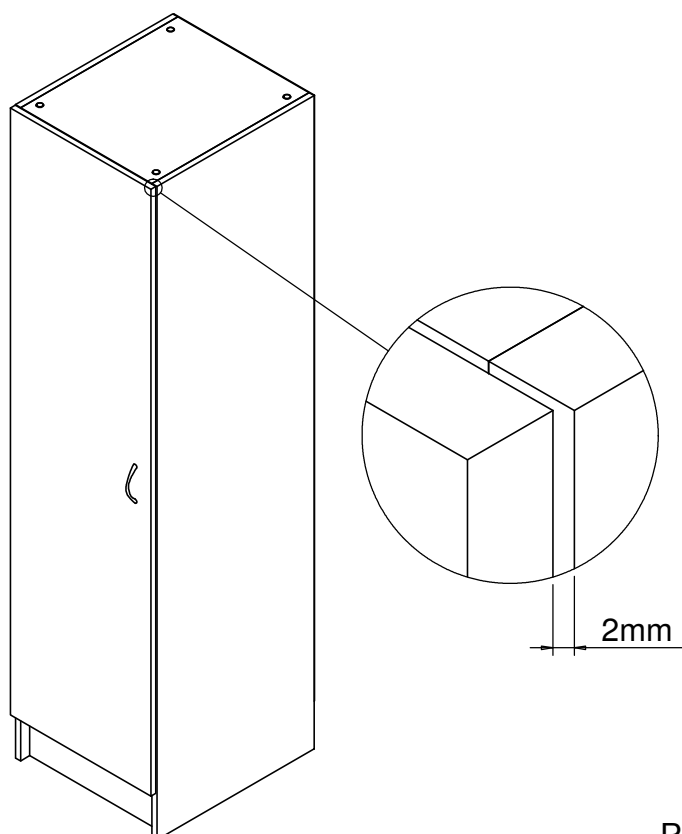
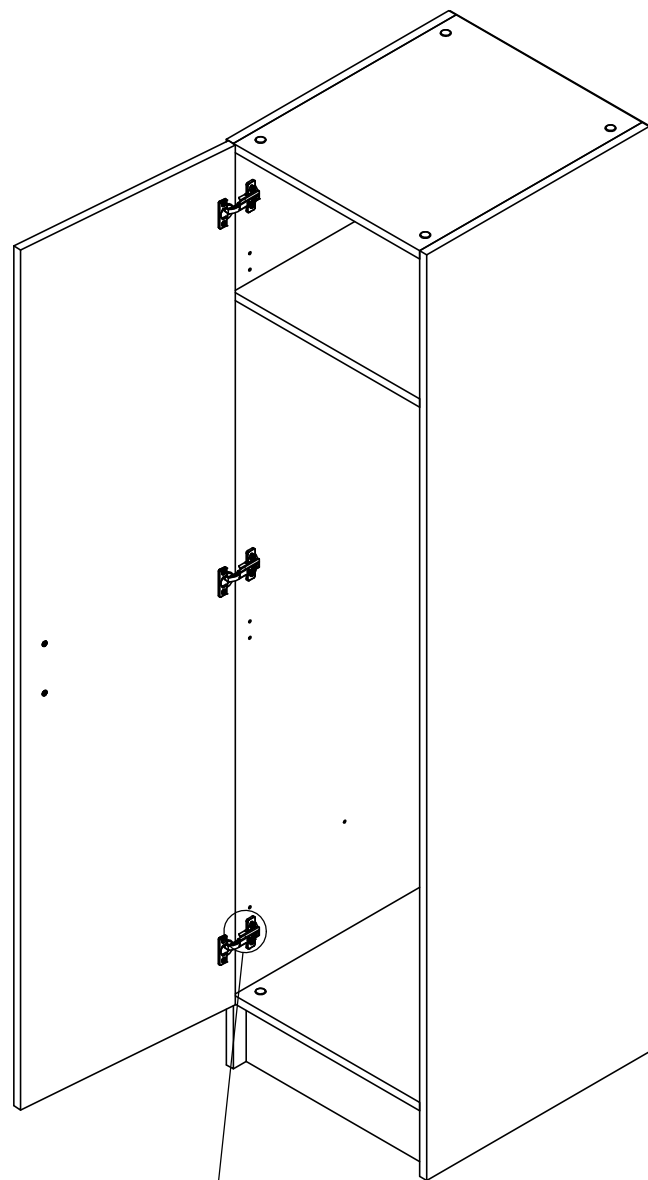



**Bedford**<sup>™</sup>  
**Furniture**



Bedford Furniture Employee – Nick Fuller

Bedford Furniture is part of the Bedford Group. Bedford is a South Australian not-for-profit organisation dedicated to enhancing the lives of people with a disability or disadvantage through employment, training, residential services and life-skills.



**Bedford**<sup>™</sup>

615 Goodwood Road, Panorama SA 5041  
PO Box 18 Melrose Park SA 5039

Telephone: 1800 822 823, Fax: (08) 8460 0009  
Email: [furniture@bedfordgroup.com.au](mailto:furniture@bedfordgroup.com.au)

[www.bedfordgroup.com.au](http://www.bedfordgroup.com.au)