



1 Door Base Unit

IMPORTANT

Before Commencing Assembly:

- Read all instructions COMPLETELY
- Ensure all listed parts are present
If any parts are missing from Parts List 1, please contact 1800 822 823.

If any parts are missing from Parts List 2, please Contact HAFELE, Australia at 1300 559 387.

- Ensure you have the required tools to complete the assembly
(Philips Head Screwdriver, Hammer & Wood Glue)

CAUTION

- Ensure your work surface is solid, level, clean and flat (DO NOT WORK ON CARPET)
- Ensure ALL melamine edges are facing as described in the Assembly Instructions.

IF YOU NEED TO CONTACT US WITH REGARD TO THIS PRODUCT PLEASE CALL **1800 822 823** AND QUOTE THE BATCH NUMBER SHOWN ON THE CARTON.

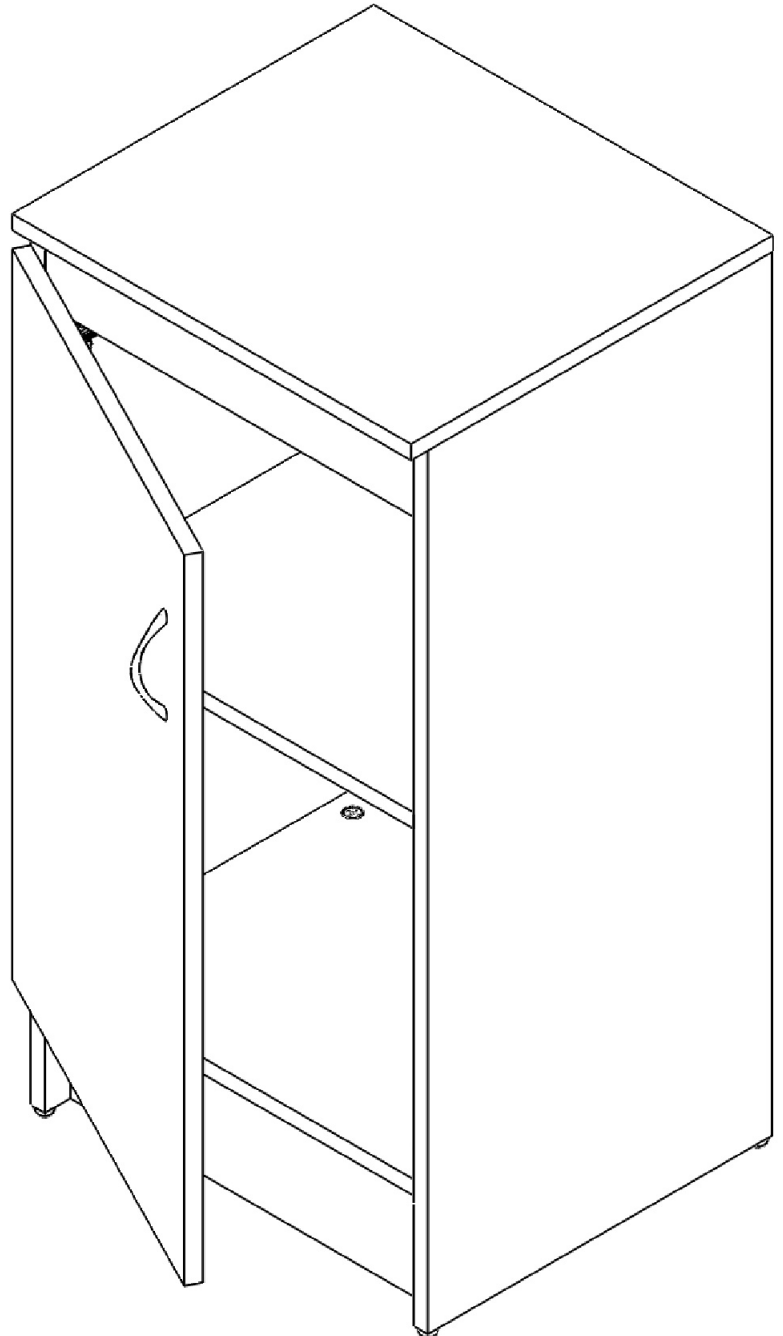

WARNING: Contains small parts, keep out of reach of children.

615 Goodwood Road, Panorama SA 5041
PO Box 18 Melrose Park SA 5039
Telephone: 1800 822 823, Fax: (08) 8460 0009
Email: furniture@bedfordgroup.com.au
www.bedfordgroup.com.au



Quality
ISO 9001

SAI GLOBAL



AUSTRALIAN MADE

Practical, Adaptable, Affordable.

READY TO ASSEMBLE HOME STORAGE SOLUTIONS

Parts List 1

1 Door Base Unit

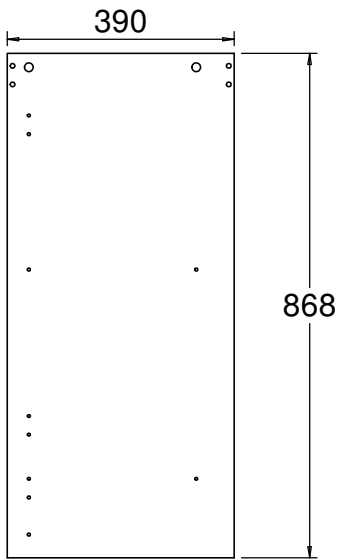

Part No.	Description	Qty.
1	LH Cabinet End	1

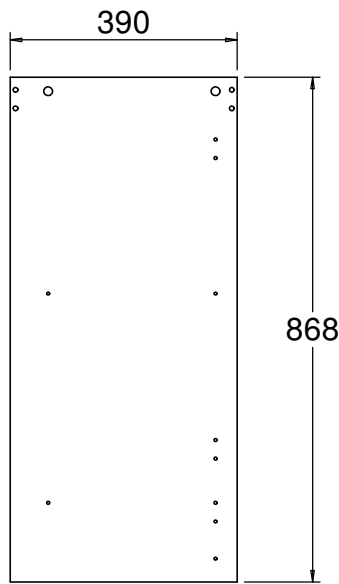

Part No.	Description	Qty.
2	RH Cabinet End	1

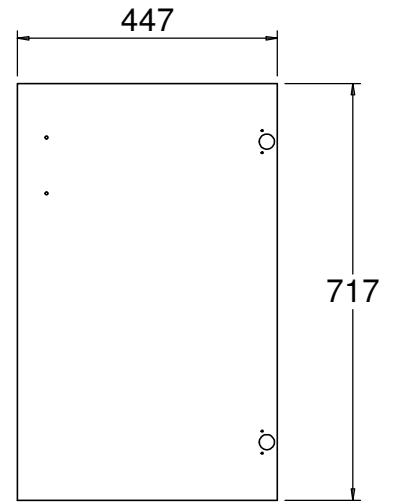

Part No.	Description	Qty.
3	LH Door	1

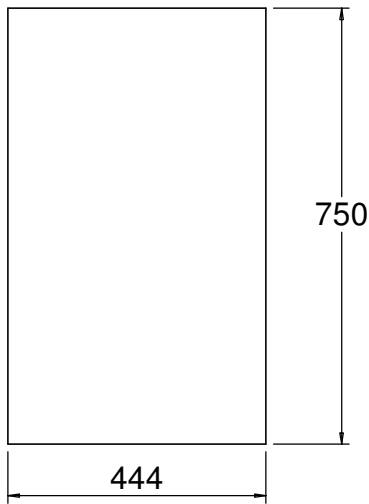

Part No.	Description	Qty.
5	Back	1

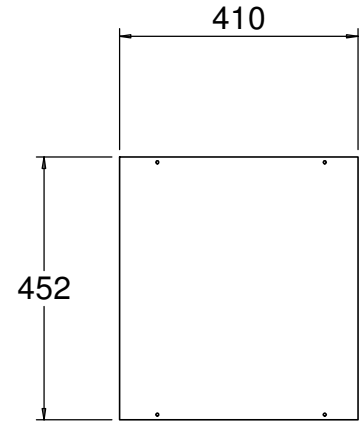

Part No.	Description	Qty.
6	Top	1

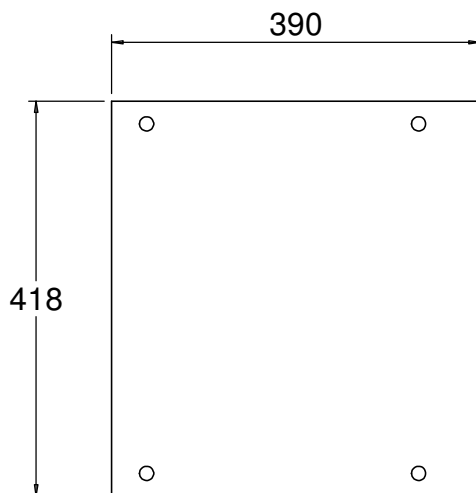

Part No.	Description	Qty.
7	Fix Shelf/Bottom	2

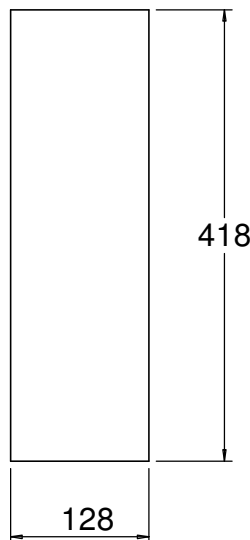

Part No.	Description	Qty.
8	Toe Rail	1

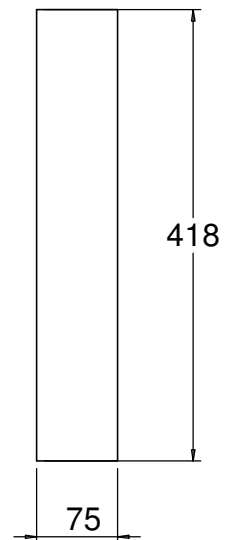

Part No.	Description	Qty.
9	Top Rail	2

Parts List 2

1 Door Base Unit

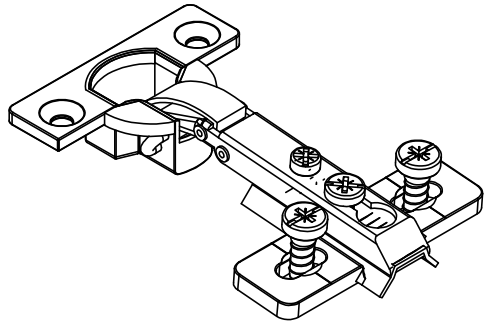

Part No.	Description	Qty.
10	Hinge	2

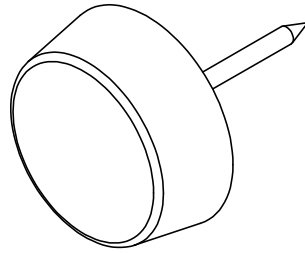

Part No.	Description	Qty.
11	Glides	4

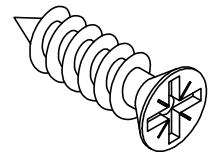

Part No.	Description	Qty.
12	Hinge Screw (15mm)	4

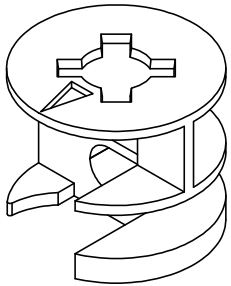

Part No.	Description	Qty.
13	Screw Cams	12

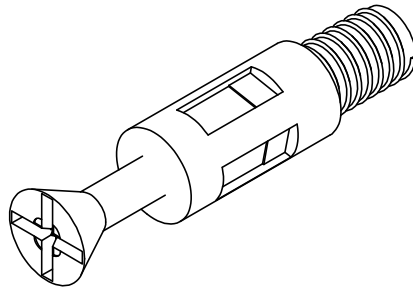

Part No.	Description	Qty.
14	Hardware Pin	12

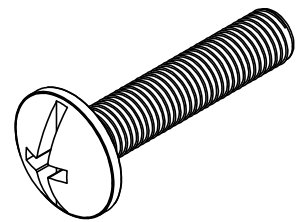

Part No.	Description	Qty.
15	Handle Screw (20mm)	2

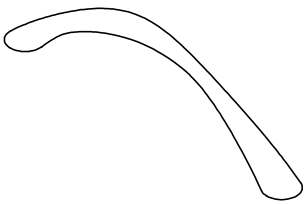

Part No.	Description	Qty.
16	Handle	1

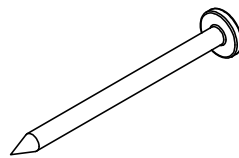

Part No.	Description	Qty.
17	Nails	25

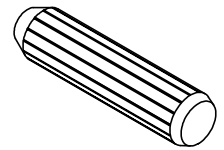

Part No.	Description	Qty.
18	Large Wooden Dowel	8

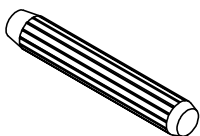

Part No.	Description	Qty.
19	Small Wooden Dowel	4

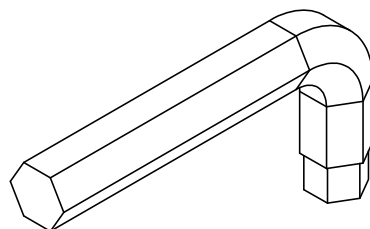

Part No.	Description	Qty.
20	Allen key (4mm)	1

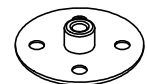

Part No.	Description	Qty.
21	Cover Caps	4

Step 1

Cabinet end panel

Please lay left cabinet end panel (1) on a flat protected surface with holes facing up. Screw the hardware pins (14) in the holes shown. Insert the screw cams (13) into the holes with arrows pointing to the top of the unit. Make sure to push the screw cams (13) all the way in by gently tapping them in with a hammer.

Loosen centre screw (2) of the hinge (10) and separate the hinge mounting plates from the hinges. Attach hinge plate to the cabinet end (1).

Assemble the right cabinet end (2) in mirror image to the left cabinet end (1).

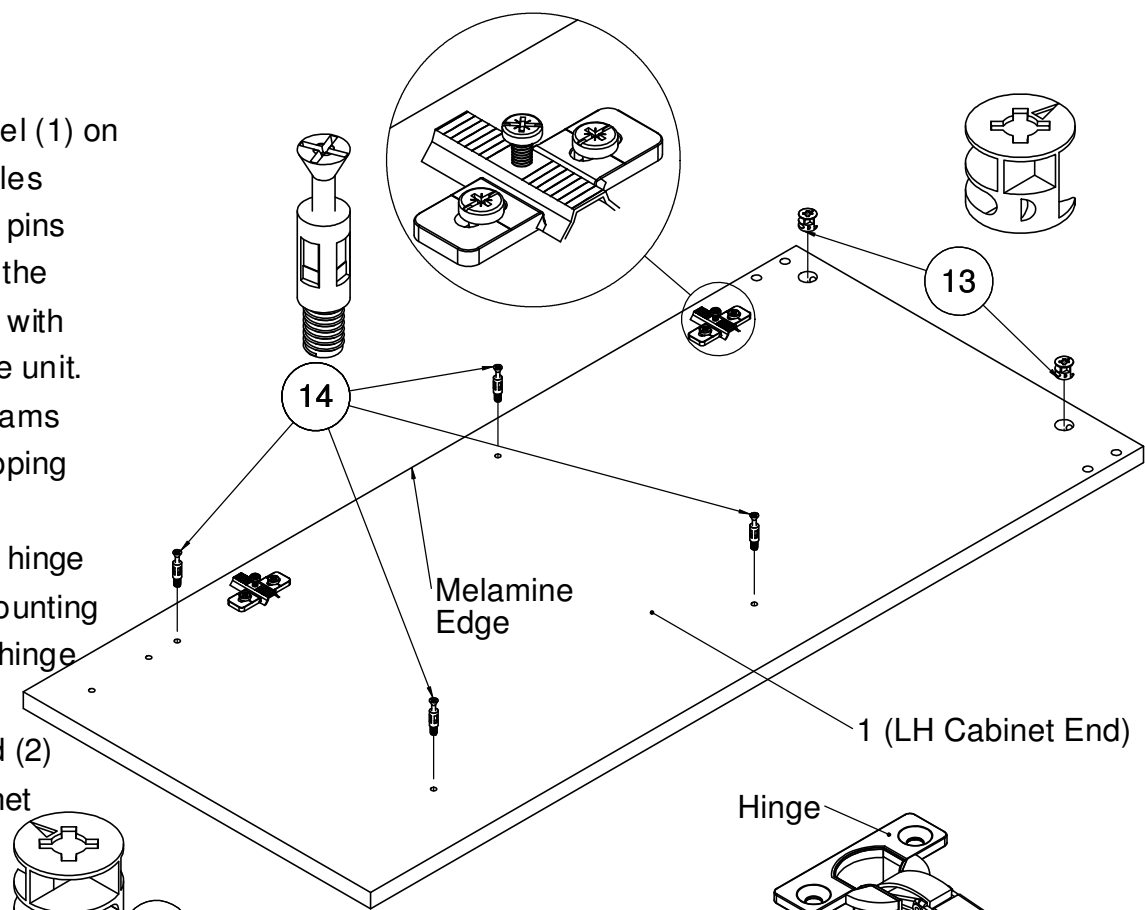

Step 2

Fix shelf, top and bottom

Lay the top (6) on a flat protected surface with holes facing up and screw the hardware pins (14). Lay the bottom (7) on a flat surface with holes facing up and insert the cams (13) in holes with arrows pointing to the side as shown. Make sure to push the cams (13) all the way in by gently tapping them with a hammer.

Repeat the step for fix shelf (7).

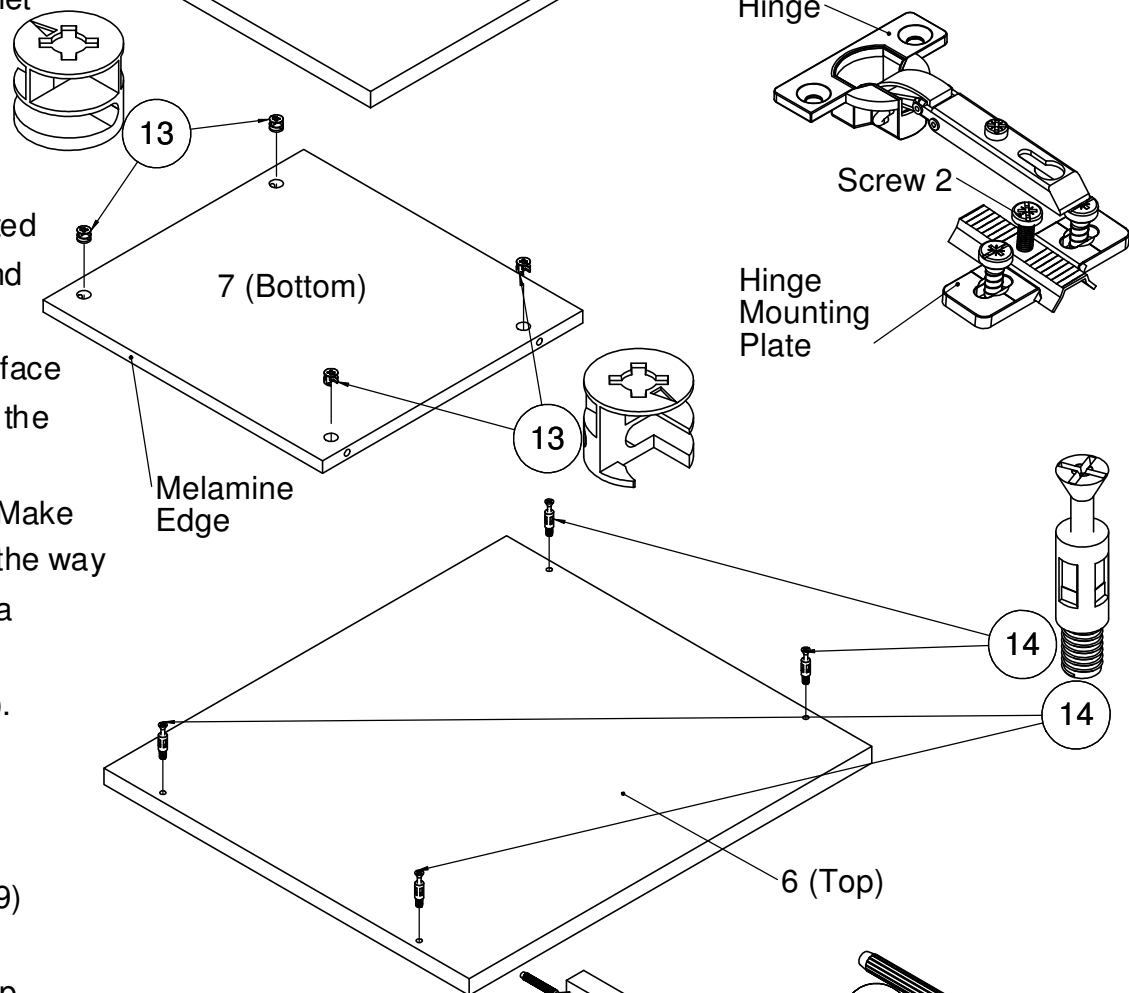

Step 3

Inserting dowels into rails

Insert small wooden dowels (19) into the toe rail (8) and large wooden dowels (18) into the top rails (9). It is recommended to use glue prior to inserting wooden dowels (18) and (19) into the holes (please remove excess glue with a damp cloth). Make sure to push the dowels (19) and (20) all the way in by gently tapping them in with a hammer.

