

2 door tall/split unit

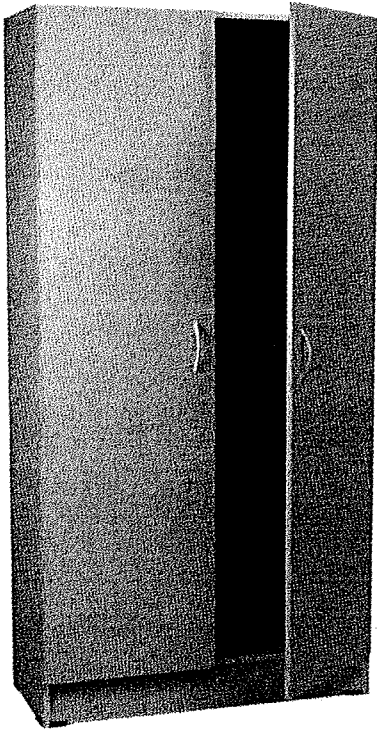

Assembly instructions



IMPORTANT ASSEMBLY HINTS

- Read all instructions through COMPLETELY before starting assembly.
- Always work on a clean, flat, solid, level surface (not carpet).
- All melamine edges must face front of unit.
- Tools needed: • hammer • Phillips head screw driver
- If any hardware components are missing from the pack, please phone Hafele Australia Pty Ltd on 1300 559 387 or (03) 9212 2000 and quote the article number on the bag.

Hardware Parts List - Check that you have the right parts and quantities.

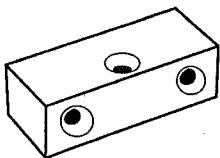

2 fixing blocks

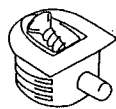

16 connectors



4 nail on glides



8 shelf supports

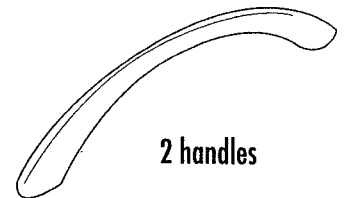

2 handles



4 handle screws

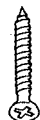

4 fixing screws



12 hinge screws



2 bags of nails



4 dowels

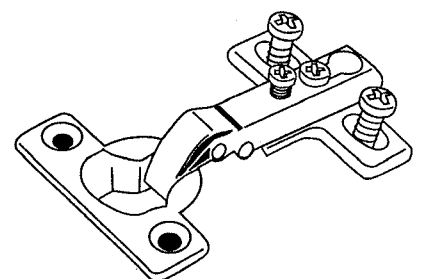

6 hinge units

Step 1

Lay both end panels on a flat, protected surface with holes facing up. Familiarise yourself with the left and right end panel hole layouts – this will make assembly easier.

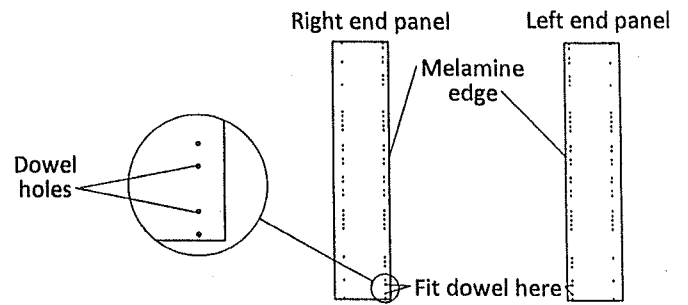

Step 2

Push dowels into 5mm holes on the inside of the two end panels.

Step 3

Separate hinge mounting plates from hinges. Secure the six hinge mounting plates to the inside of both end panels (three on each panel) using the two attached screws supplied.

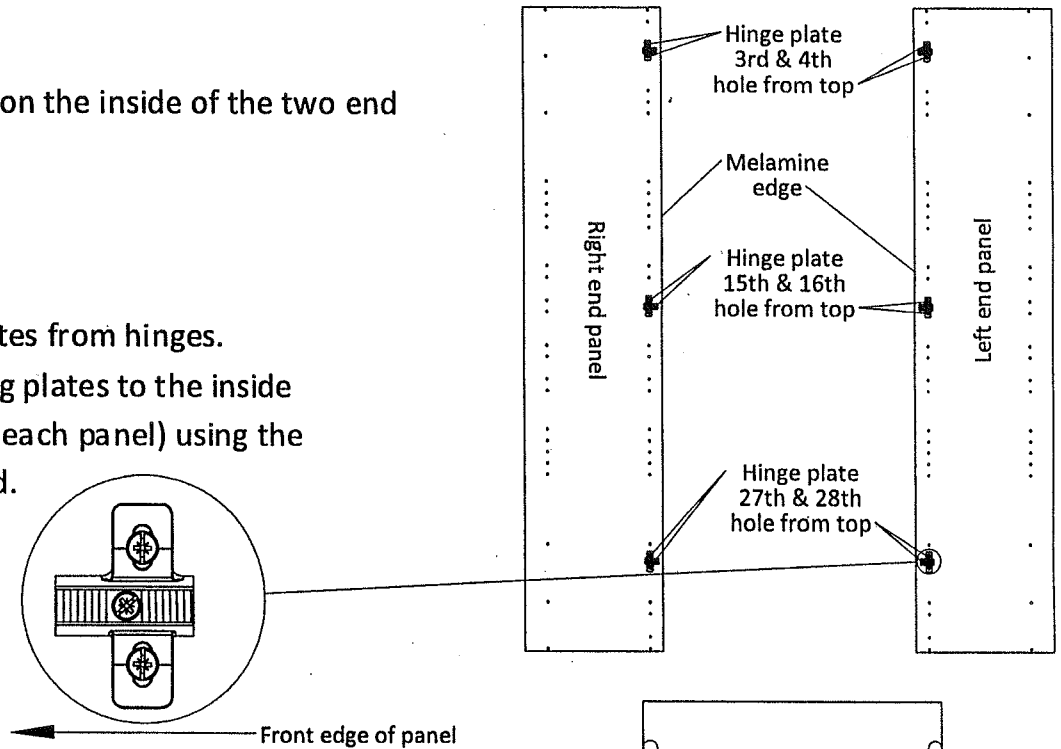

Step 4

Lay the three pre-board panels (top, fix shelf & Bottom) on a flat surface with holes facing upward. Push the connectors into the holes as shown in the diagram.

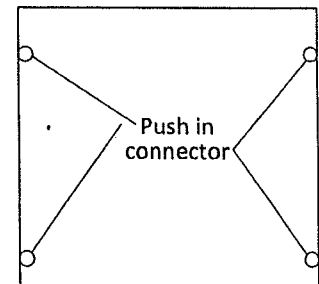

Step 5

With the right end panel lying flat and with its melamine edge on the left side, fix the bottom rail to the two wooden dowels.

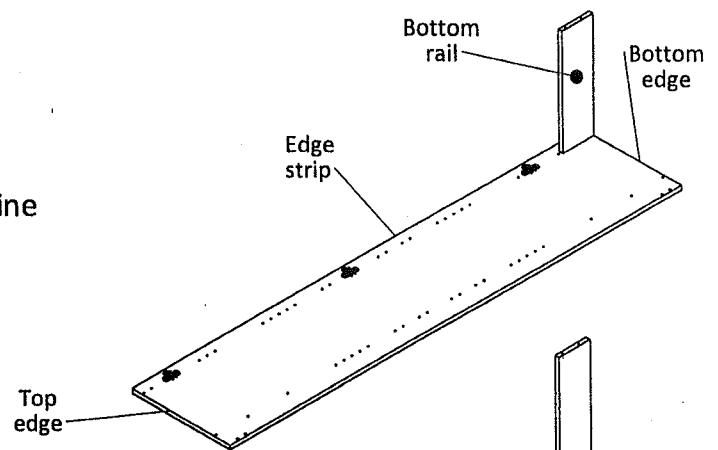

Step 6

Attach the top with connector facing up. Please make sure that the top is pushed tightly against the end panel before tightening the screws.

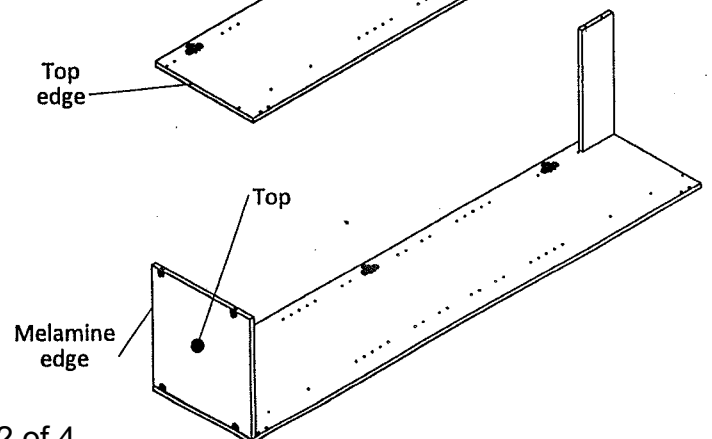

Step 7

Attach the bottom with connector facing up.
Make sure that the bottom is pushed tightly
against the end panel before tightening the screws.

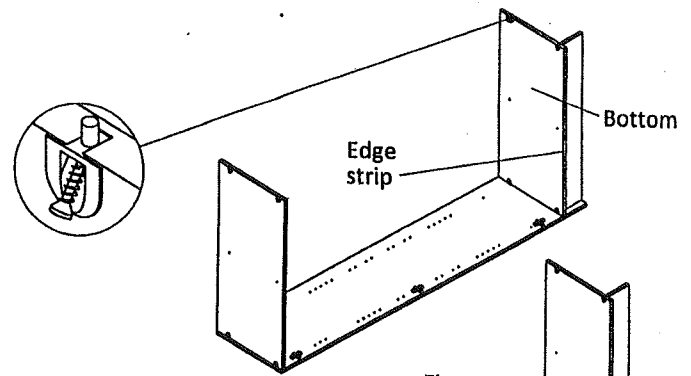

Step 8

Attach the fix shelf with connectors facing down and melamine
edge front of the unit. Please make sure that the fix shelf is
pushed tightly against the end panel before tightening the screws.

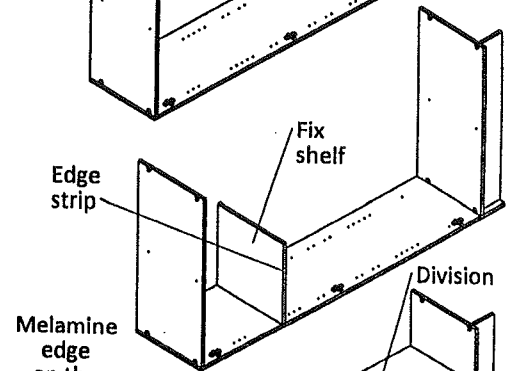

Step 9

The division fits between the top and bottom. Please insert the
division among the top and bottom making sure that boring
(connectors) are facing the left hand side panel. The fix shelf
can now be attached to the division.

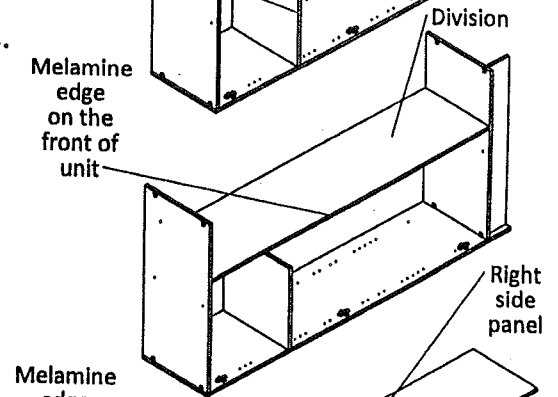

Step 10

Attach the right side panel by locating dowels and holes. Secure
with connectors.

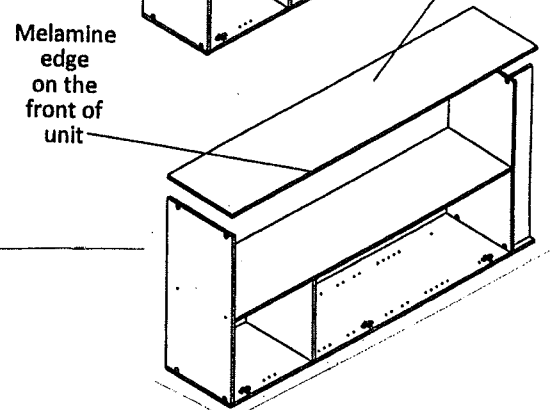

Step 11

Attaching back panels - lay unit face down on a protected surface to
avoid damaging the front melamine edges (raw edges facing upwards).
Position one of the back panels against the top rear of the unit
(approximately 3mm in from the edge) with white side facing inward.
Ensure cupboard is square, nail into position along all edges, taking care
to avoid nails breaking through the surface of the shelf.

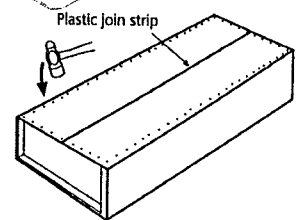

Step 12

While unit is laying face down attach the four nail on gliders to the
underside corners of the end panels. Stand the cupboard upright.

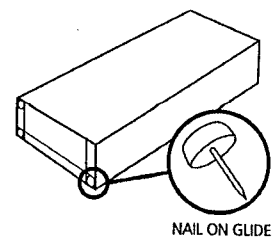

Step 13

Fit the shelf supports and adjustable shelves into position.

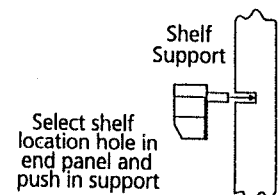

Step 14

Lay both door panels on a solid flat, protected surface with holes facing upwards. These panels are identified by large 26 diameter holes

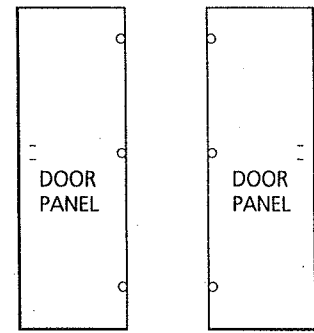

Step 15

Attach hinges to inside of door panel - Position body of hinge in large 26mm hole and screw in place using hinge screws provided. Repeat for other five hinges.

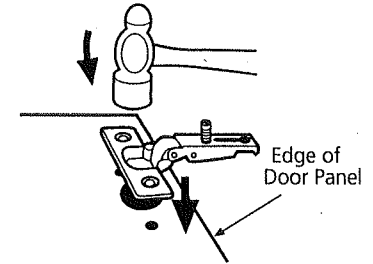

Step 16

Attach doors to cupboard (hinges on inside in open position) by fitting hinges over hinge plates and sliding doors along. Tighten retaining screws.

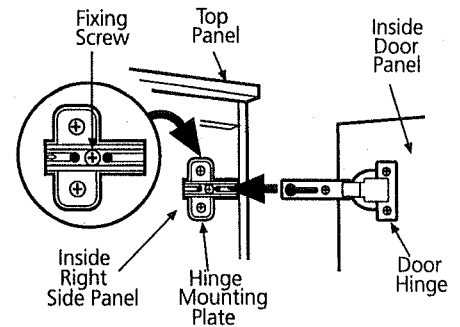

Step 17

Adjust door gap with hinge adjustment screw.

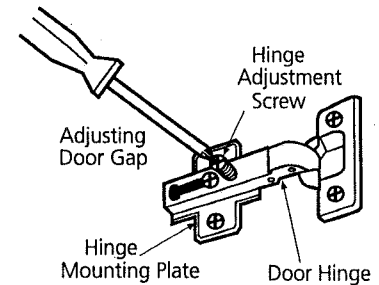

Step 18

Fix handles onto doors using screws provided.

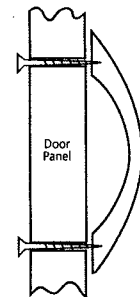

Step 19

Fixing blocks and fixing screws are provided to attach to the cupboard for securing to a wall. Screws for attaching to wall are not included in pack.

Assembly completed, well done! If you have need to contact us regarding this product please call 1800 822 823 quote the batch number shown on the carton.