

HMR Solutions 2 Door Wall Cabinet 600mm

IMPORTANT

Before commencing Assembly:

- Read all instructions COMPLETELY.
- Hardware kit contains small parts; keep out of reach of children.
- Ensure all listed parts are present.
- Required tools to assemble:
Philips head screw driver, Hammer & Wood Glue.
- Required assembly work surface should be solid, level, clean and flat.
- Ensure all melamine edges are facing to the front of the unit.

Customer Services Enquiries 1800 822 823

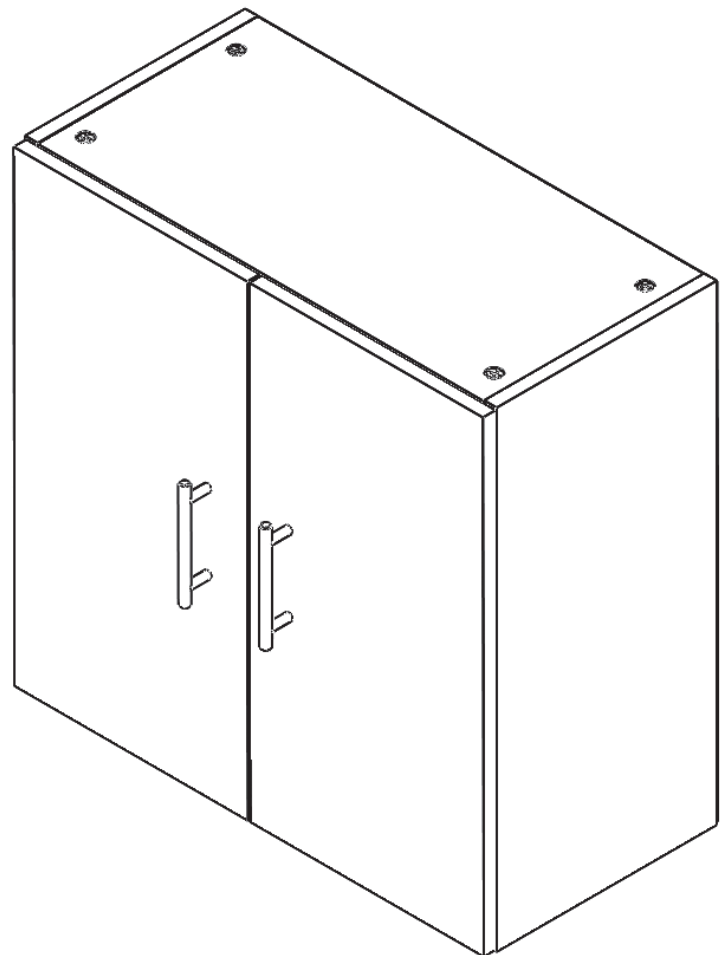

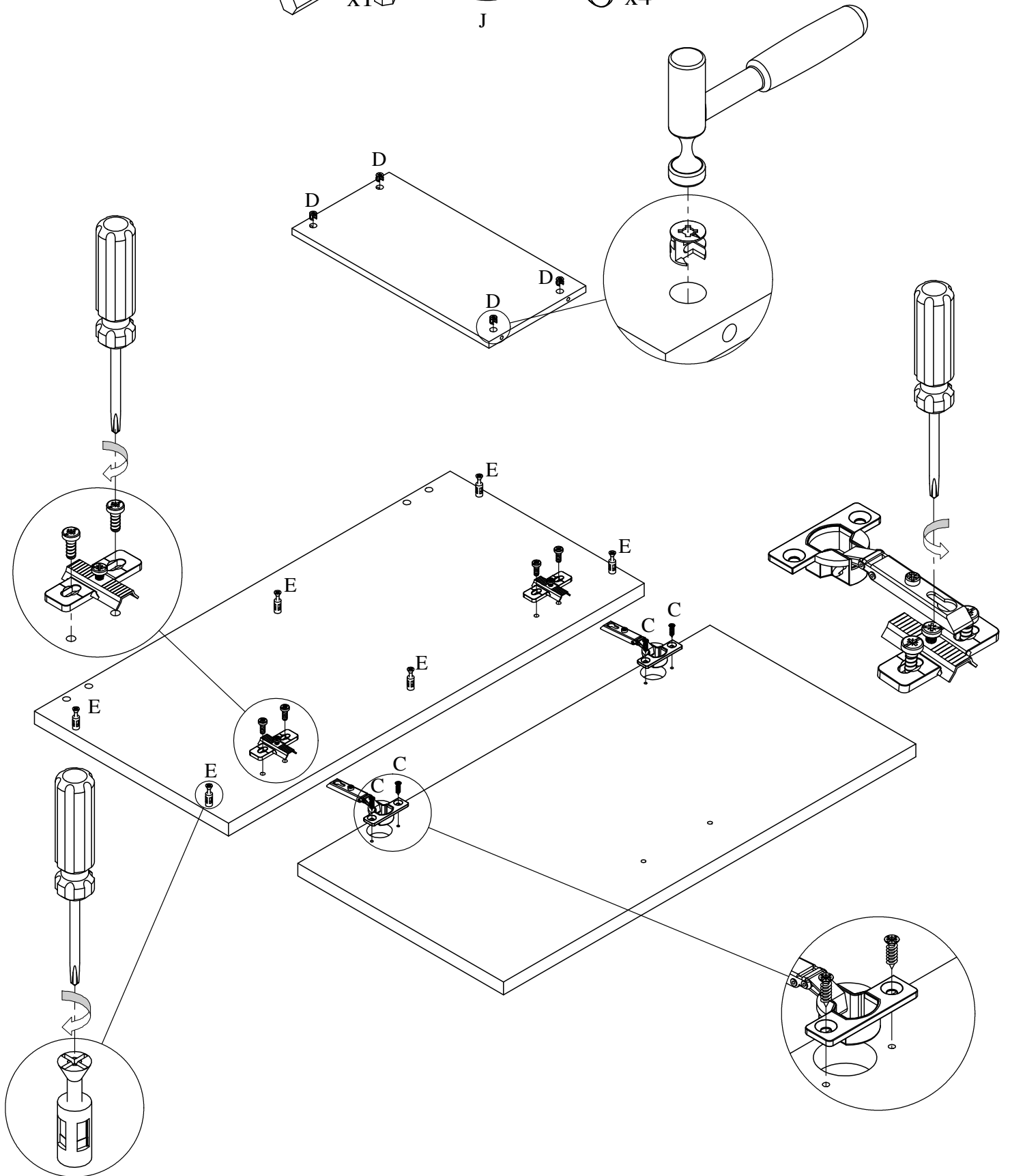
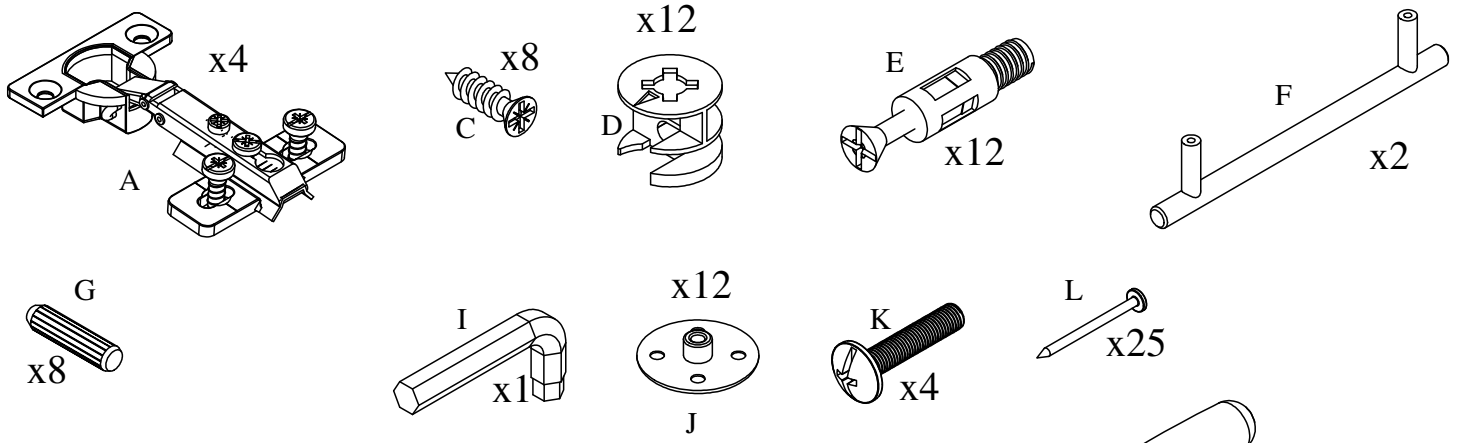

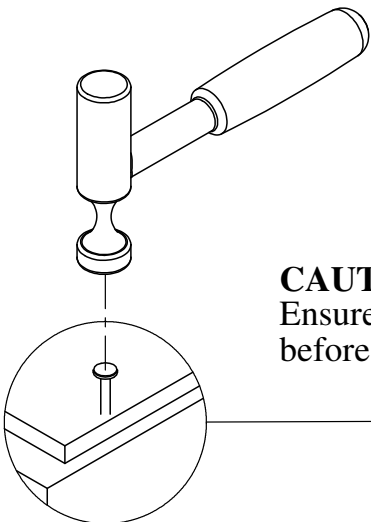
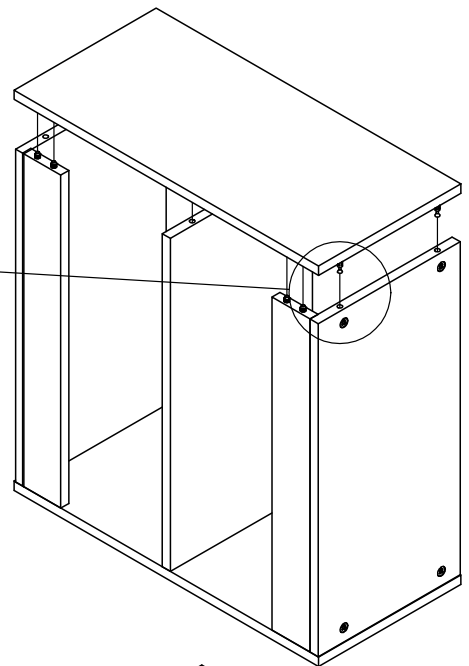
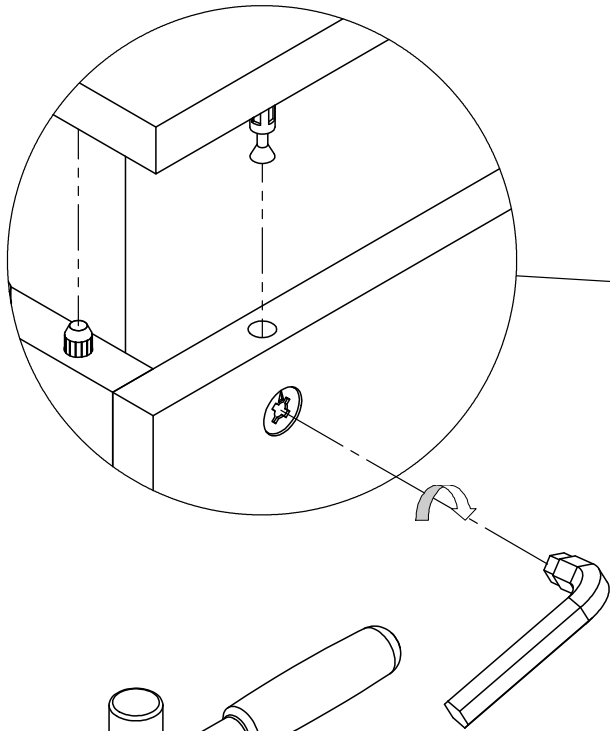
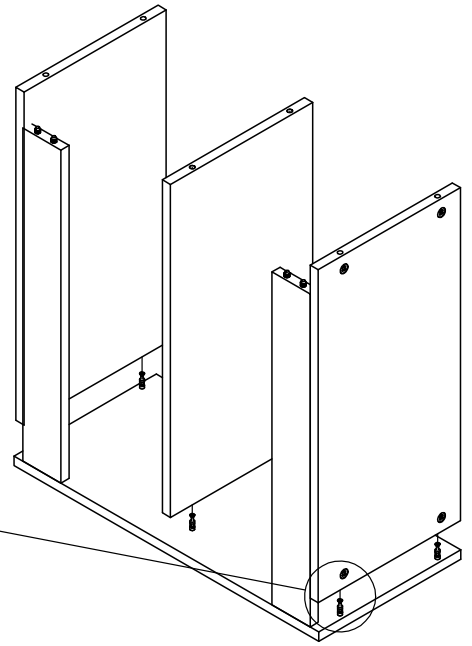
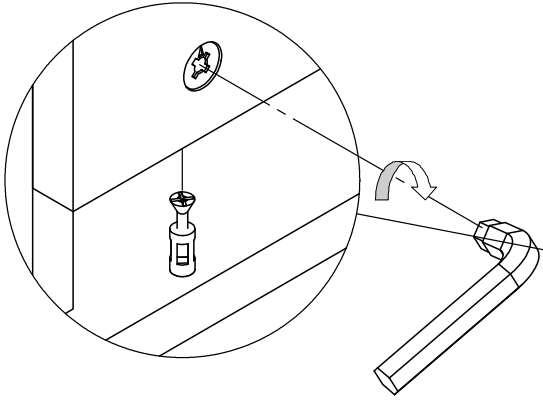
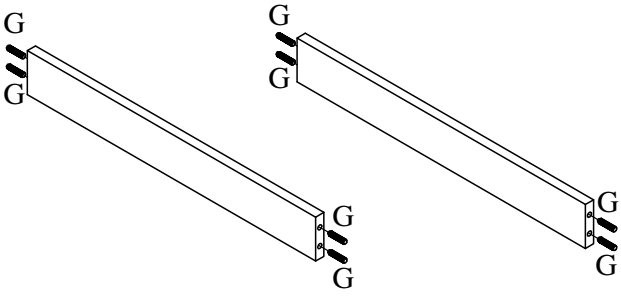

CAUTION:
Ensure Cupboard is square
before nailing back panel.

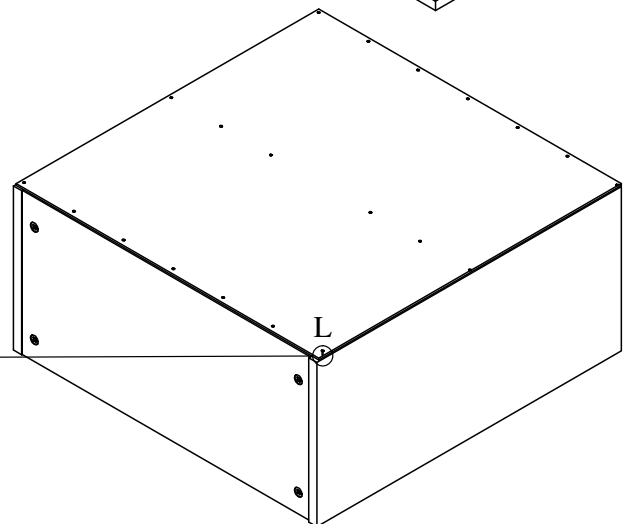

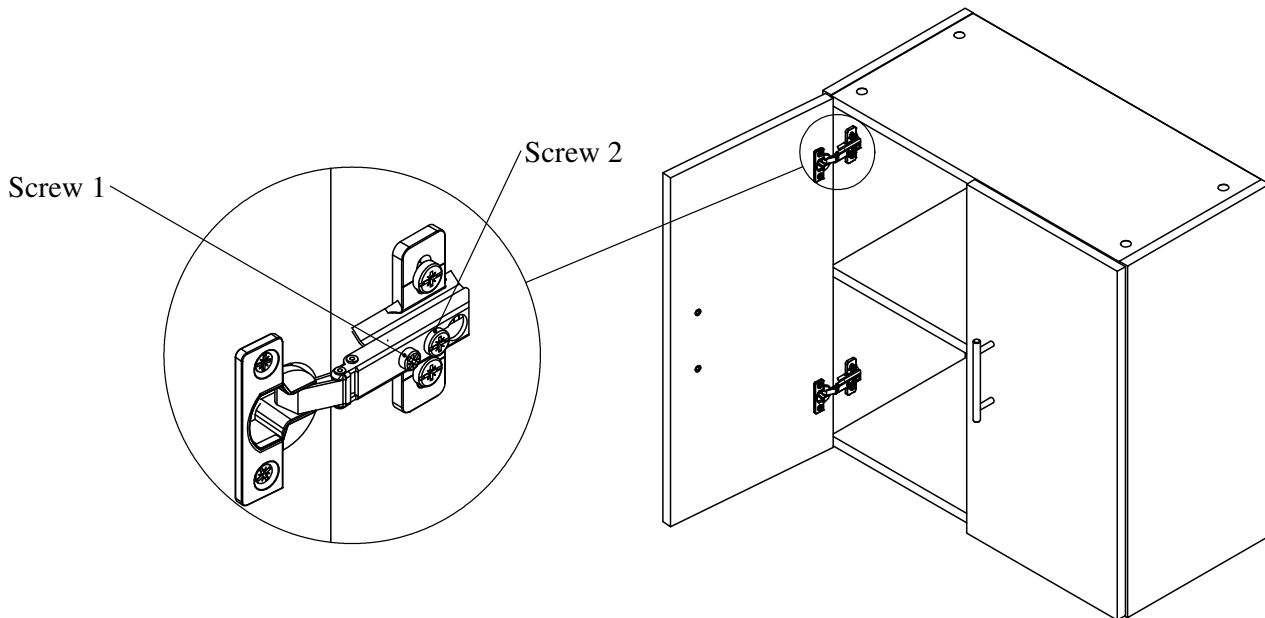
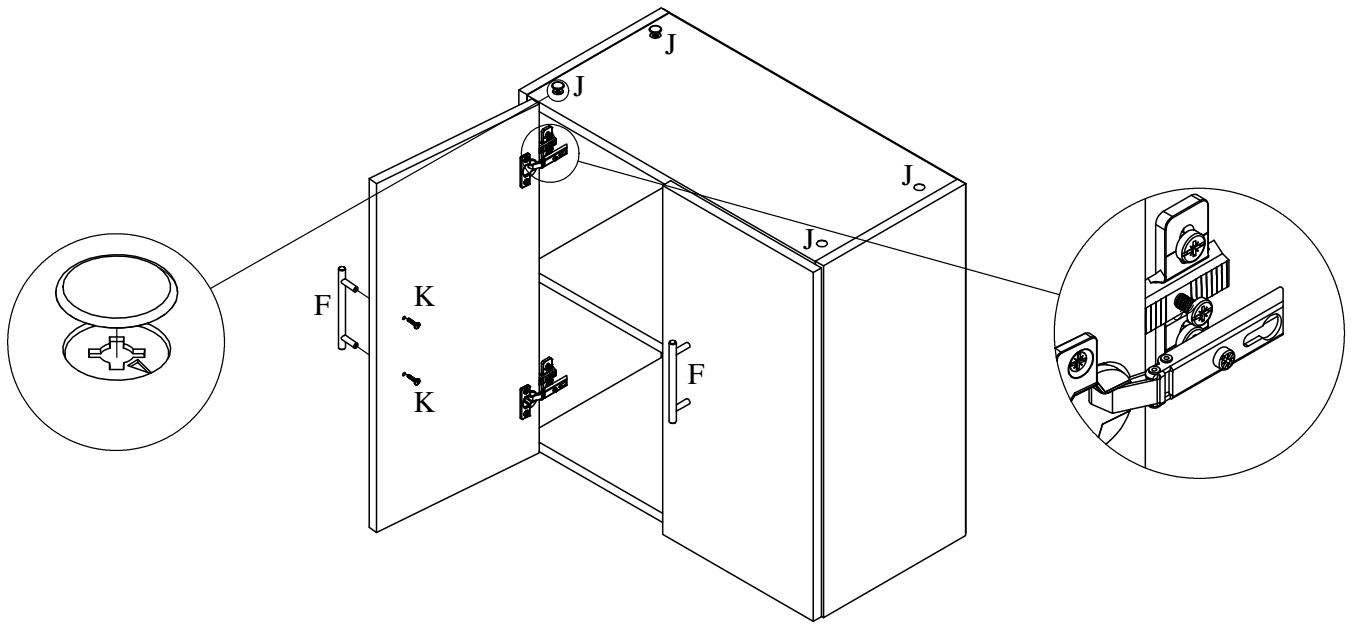

- Screw 1 is used for adjustment
- Screw 2 is used to secure hinge to end

The following instructions show how to adjust hinges if the gap between the doors is too wide.

1. Start from the top hinge
2. Loosen *screw 2* by turning screw in an anti-clockwise direction.
3. Now turn screw 1 in a clockwise direction (the amount to turn this screw is determined by the width of the gap between the doors).
4. Tighten screw 2 by turning in a clockwise direction
5. Repeat these steps for the centre hinge and bottom hinge
6. Repeat these steps again with the other door
7. Check gap between doors (should be approx 2mm), if not repeat steps 1 to 5.